

STORAGE

Basic Sideboard



STORAGE

Basic Sideboard

Technical specifications

The SIDEBOARD collection is a modular system developed combining STORAGE CONTAINERS and SISTEMA45 MODULES. Combinations of different volumes, colors and materials, give shape to original storage solutions. The system includes 8 standard configurations, in addition to the possibility of creating infinite compositions, thanks to the combination of various modules.

Each sideboard consists of the following items:

- STORAGE CONTAINERS with doors or open
- SISTEMA45 MODULES with doors or open
- Finishing top and sides
- PUSH PULL accessory for door opening
- Special feet

The use of wall unit modules emphasizes a special CARE OF THE DETAIL through the 45 ° processing among top, sides and base.

The use of the comfortable push-pull opening mechanism on the fronts of the STORAGE CONTAINERS adds ESSENTIAL and CLEAN AESTHETIC to the entire composition.

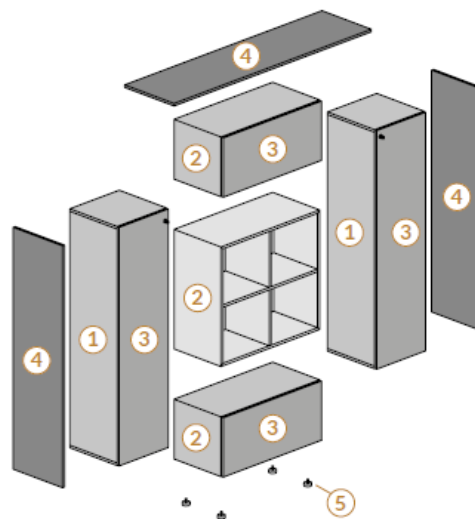
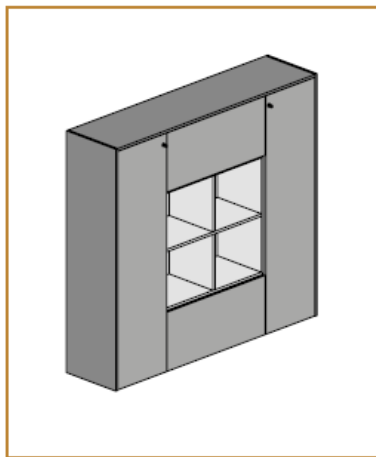

- 1 **Struttura contenitori**
Storage unit structure
Structure armoires
- 2 **Struttura pensili**
Wall units structure
Structure éléments hauts
- 3 **Ante melaminico**
MFC doors
Portes en mélaminé
- 4 **Top e fianchi di finitura**
Finishing top and sides
Top et cotés de finition
- 5 **Piedini**
Feet
Pieds

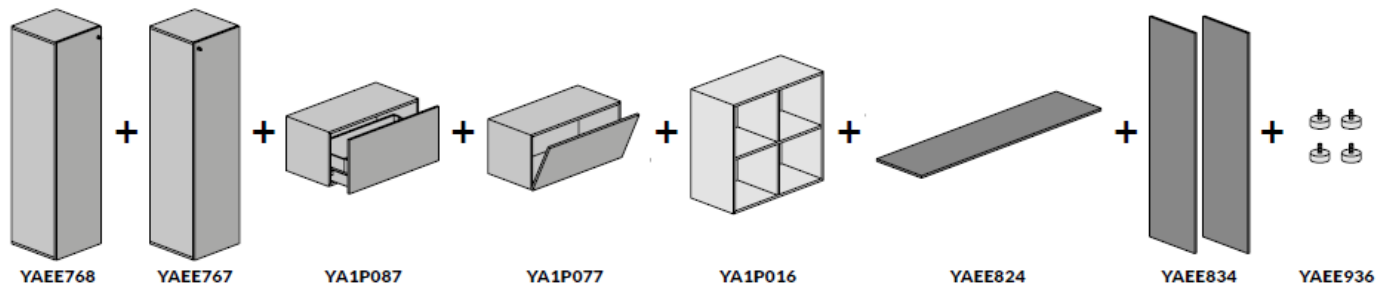

NOTES

- Attention: the wall units placed as a base on the ground need to be fitted with feet YAAE936.

STORAGE

Basic Sideboard

Technical specifications

STORAGE UNITS - STRUCTURE

Structure consisting of base, top, two sides 18mm thick. Back inserted in milled 18mm thick. Shelves 25mm thick equipped with hardware for concealed fixing, which can be positioned on the holes in the sides, 32mm pitch. Structure made of scratch-resistant and anti-reflective class E1 melamine particleboard panels on two sides. Equipped with height-adjustable feet in black nylon (4 on cabinets L.450mm and 5 on cabinets L.900mm), with 15mm adjustment. Available in 2 melamine colors.

SISTEMA45 MODULES - STRUCTURE

Structure consisting of base, top and two sides joined with 45° processing. Rear panel inserted in milled, with predisposition bracket for hooking to the wall. Made with 18mm thick particle board panels in 2 versions:

- E1 class scratch-resistant and anti-reflective melamine on two sides, with 1mm thick ABS perimeter edges;
- micro-structured matt lacquered with polyurethane paints.

Equipped with adjustable bracket for fixing on masonry (no plasterboard). Made in 3 heights. Available in 3 melamine colors and 19 lacquers. Max capacity for single element 25Kg.

STORAGE UNITS - DOORS, TOP AND SIDES - MELAMINE

Made with 18mm thick particle board panels with E1 class anti-scratch and anti-reflective melamine on two sides. Doors equipped with adjustable hinges with quick fixing. Hinges with 110° opening. Doors including lock with removable cylinder, supplied with double numbered and accident prevention folding key. Opening system with Push & Pull mechanism and soft closing hinges. Available in 7 finishes.

STORAGE UNITS - DOORS, TOP AND SIDES - LACQUERED

Made with 18mm thick particle board panels, class E1 melamine on two sides and micro-structured matt lacquered with polyurethane paints. Doors equipped with adjustable hinges with quick fixing. Hinges with 110° opening. Doors including lock with removable cylinder, supplied with double numbered and accident prevention folding key. Opening system with Push & Pull mechanism and soft closing hinges. Available in 19 colors.

STORAGE UNITS - DOORS, TOP AND SIDES - VENEER

Made with wood fiber panel, density 650 kg / mc, in class E1, veneered with Alpi multilaminar wood veneer according to ISO 18775. Surface finish open pore. SEMI-GLOSS painting with non-toxic, antireflective transparent acrylic paints. 18mm thick panels with perimeter edges in 1mm thick wood veneer. Opening system with Push & Pull mechanism. Available in 2 essences: i1WE, i1RO. Doors equipped with adjustable hinges with quick fixing. Hinges with 110° opening. Doors including lock with removable cylinder, supplied with double numbered and accident prevention folding key. Opening system with Push & Pull mechanism and soft closing hinges.

STORAGE UNITS - DOORS, TOP AND SIDES - VENEER MATT FINISH

Made with wood fiber panel, density 650 kg / mc, in class E1, veneered with Alpi multilaminar wood veneer according to ISO 18775. Surface finish open pore. SUPER-MATT matt varnish with non-toxic transparent acrylic paints, anti-reflective and velvety to the touch. 18mm thick panels with perimeter edges in 1mm thick wood veneer. Available in 4 essences: i2NR, i2NT, i2PA, i2EB. Doors equipped with adjustable hinges with quick fixing. Hinges with 110° opening. Doors including lock with removable cylinder, supplied with double numbered and accident prevention folding key. Opening system with Push & Pull mechanism and soft closing hinges.

STORAGE

Basic Sideboard

Technical specifications

STORAGE UNITS - DOORS, TOP AND SIDES - VENEER BRUSHED FINISH

Made with wood fiber panel, density 650 kg / mc, in class E1, veneered with Alpi multilaminar wood veneer according to ISO 18775. Surface finish BRUSHED. SUPER-MATT matt varnish with non-toxic transparent acrylic paints, anti-reflective and velvety to the touch. 18mm thick panels with perimeter edges in 1mm thick wood veneer. Available in 4 essences: i3NR, i3NT, i3PA, i3EB. Doors equipped with adjustable hinges with quick fixing. Hinges with 110° opening. Doors including lock with removable cylinder, supplied with double numbered and accident prevention folding key. Opening system with Push & Pull mechanism and soft closing hinges. Wood brushing is a process that gives the material a natural and material effect, highlighting the grain of the wood. This treatment is done with special machines which, through the mechanical action of brushes, remove the softer parts of the wood present on the surface. The wood grain is highlighted, enhancing all the beauty of the wood.

SISTEMA45 MODULES - MELAMINE, LACQUERED, VENEERED FRONTAL

Made with 18mm thick particle board panels in 3 versions:

- E1 class scratch-resistant and anti-reflective melamine on two sides, with 1mm thick ABS perimeter edges;
- micro-structured matt lacquered with polyurethane paints;
- veneered with Alpi multilaminar wood veneer according to ISO 18775, and painted with non-toxic, anti-reflective transparent acrylic paints.

Available with side hinged opening, bottom or flap hinged and pull-out drawer. Push & Pull opening system and for the side hinged opening doors included also soft closure mechanism. Fronts available in all finishes of the melamine, lacquered and veneered collection.

FINISHED TOP AND SIDES - COVERED IN LEATHER

Made with 18mm thick particle board panels, class E1 melamine on two sides, and covered in leather on the upper side and edges, with matching stitching. Semianiline treated cowhide with a finished thickness of 1.0 - 1.2 mm. Item with a soft hand, waxy touch and semi-opaque appearance. Available in 6 leather colors.

Abacus

Madia BASIC | BASIC Sideboard | Buffet BASIC

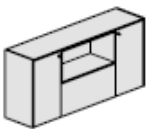

L180P45H85

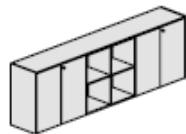

L270P45H85

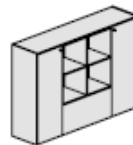

L180P45H127

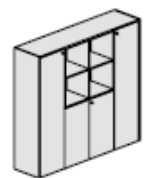





































































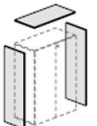

L180P45H168

STORAGE

Basic Sideboard

Finishes

<p>Struttura contenitori Storage unit structure Structure armoires</p>		<p>Melaminico Melamine Méลามine</p> <p> </p> <p>N3BD N3NJ</p>
<p>Struttura pensili Wall units structure Structure éléments hauts</p>		<p>Melaminico Melamine Méลามine</p> <p>  </p> <p>N3BD N2GF N3NJ</p>
<p>Struttura pensili Wall units structure Structure éléments hauts</p>		<p>Laccato Lacquered Laqué</p> <p>         </p> <p>L2BD L2GC L2ME L2GF L2SI L2CS L2GL L2CN L2MS L2VO</p> <p>       </p> <p>L2SA L2VF L2OT L2DE L2BV L2NU L2TT L2MK L2NE</p>
<p>Ante, top e fianchi Doors, finishing top and sides Portes, top et panneaux latéraux</p>		<p>Melaminico Melamine Méลามine</p> <p>   </p> <p>N3BD N3RV N3NB N3EU</p> <p>  </p> <p>N2GF N3NJ N3FC</p>
<p>Ante, top e fianchi Doors, finishing top and sides Portes, top et panneaux latéraux</p>		<p>Laccato Lacquered Laqué</p> <p>         </p> <p>L2BD L2GC L2ME L2GF L2SI L2CS L2GL L2CN L2MS L2VO</p> <p>       </p> <p>L2SA L2VF L2OT L2DE L2BV L2NU L2TT L2MK L2NE</p>
<p>Ante, top e fianchi Doors, finishing top and sides Portes, top et panneaux latéraux</p>		<p>Impiallacciato Wood Veneer Bois Plaqué</p> <p> </p> <p>i1RO i1WE</p> <p>       </p> <p>i2NR i2NT i2PA i2EB i3NR i3NT i3PA i3EB</p>
<p>Top e fianchi Finishing top and sides Top et panneaux latéraux</p>		<p>Pelle Leather Cuir</p> <p>     </p> <p>P1BG P1MS P1VP P1BN P1CG P1NE</p>